

# 8206/8207/8208老人椅装配流程图

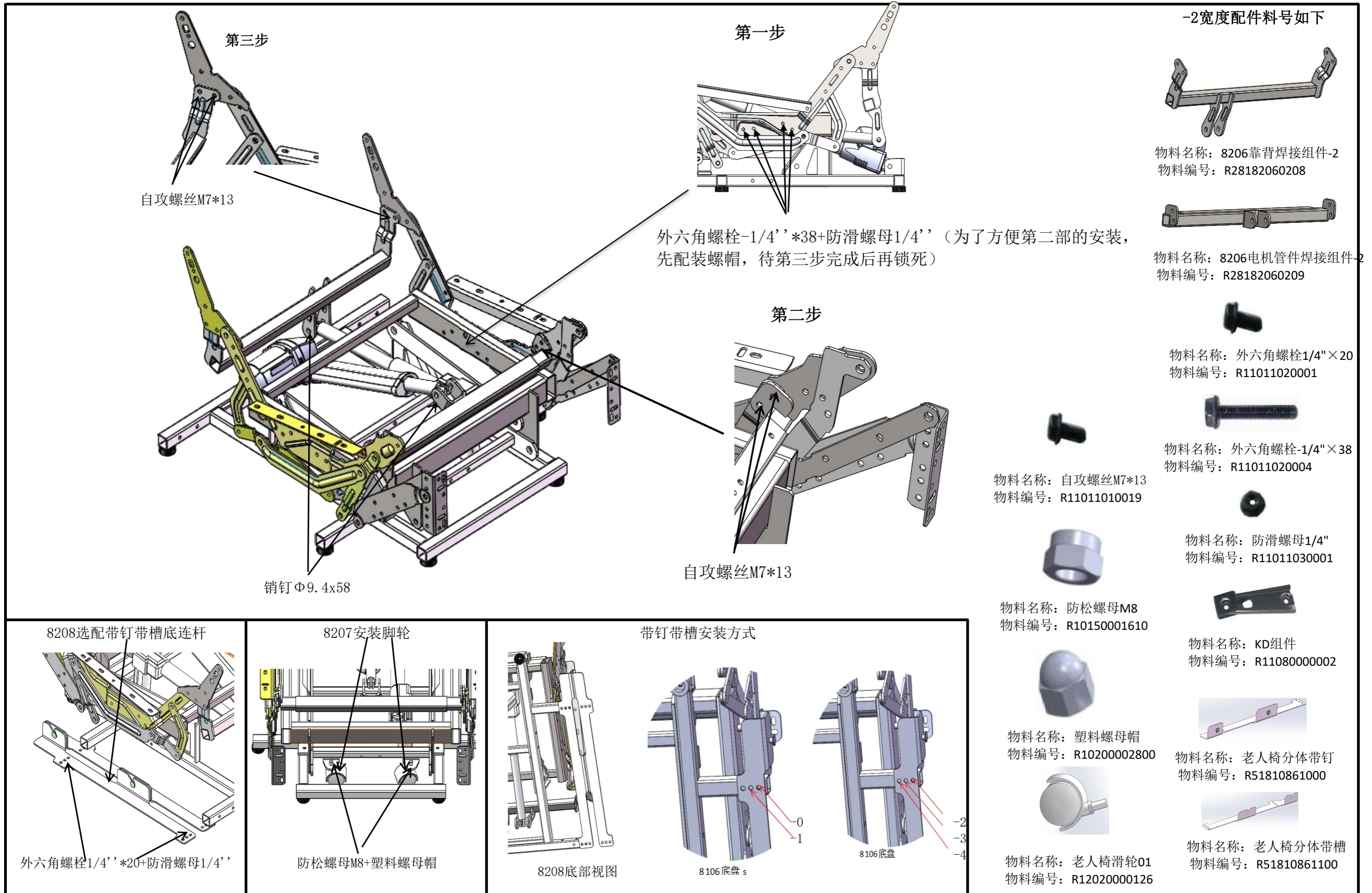

编制:

审核:

批准: